

# SHVC(Scalable HEVC) Experiment: 360 VR Video Service with 16K Resolution based on Tiled Adaptive Streaming

Presenter: Jong-Beom Jeong (uof4949@skku.edu)

SoonBin Lee, Jong-Beom Jeong, Eun-Seok Ryu

Multimedia Computing Systems Lab. (MCSL)

<http://mcsl.skku.edu>

Department of Computer Education

Sungkyunkwan University

# Scalable HEVC(SHVC)

- Background
  - For Scalable HEVC
  - Multi-layer Structure (Base layer and Enhancement layer)
  - Inter-layer prediction for referencing between two layers

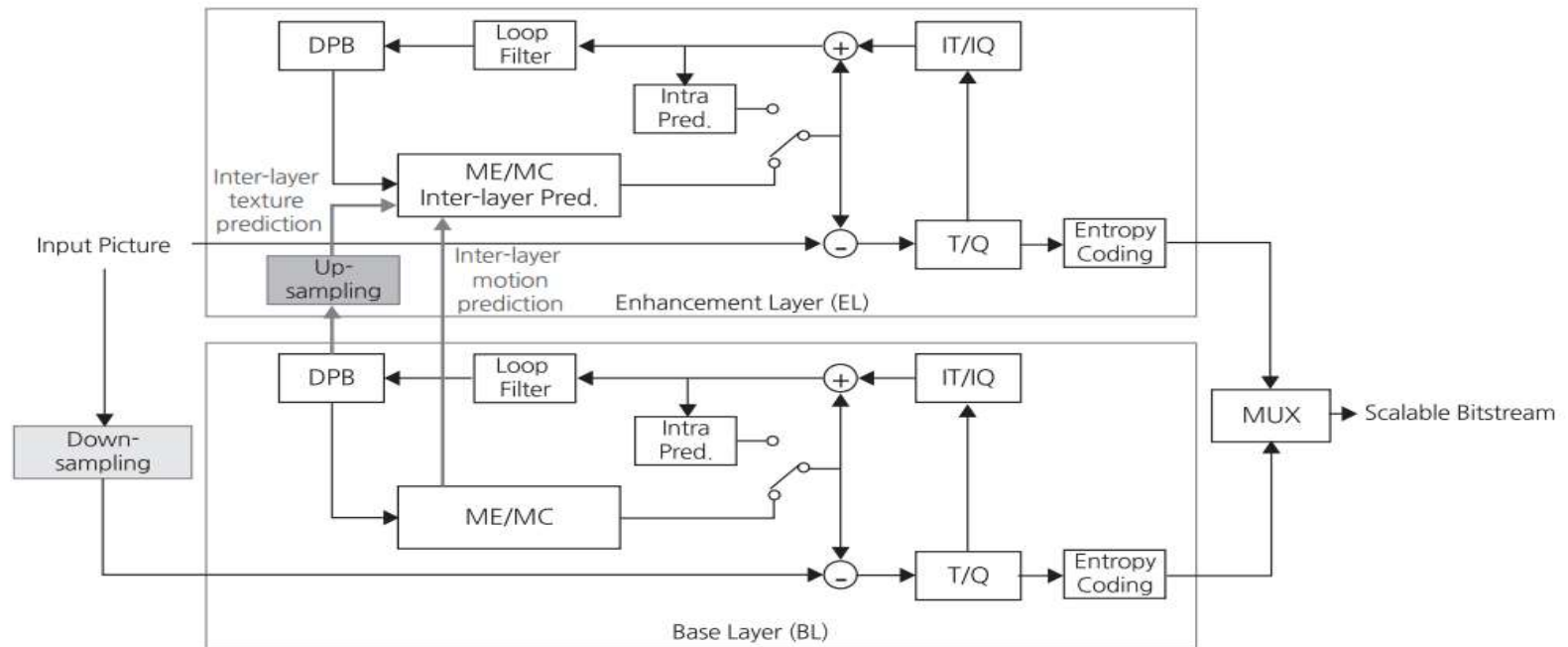

Architecture of SHVC

# Tiled Adaptive Streaming

- Background
  - Multi Layered Rendering 360 VR
  - ROI-based HEVC tiled adaptive streaming for 360 VR video



360 VR Tile Streaming for User's Viewport

# Test Sequences

- Test Sequences



Lake Park Riding 16K



Ilsan KINTEX Drone 16K

Sequence name	Resolution	Frame count	Frame rate
Lake Park Riding 16K	15360x7680	300	30
Ilsan KINTEX Drone 16K	15360x7680	300	30

# Experimental Results

- Server
  - 2 linux servers (ubuntu 16.04) were used in experiment
  - One has 2 intel xeon E5-2687w (12 cores, 24 threads) CPUs and 128GB memory
  - Another has 2 intel xeon E5-2620 (6 cores, 12 threads) CPUs and 128GB memory
  - Memory requirement is very high in SHM encoding process (>50GB)
- Software
  - SHM 12.0
  - HM 16.9

# Experimental Results (-Cont'd)

- Experimental results for *Lake Park Riding 16K* and *Ilsan KINTEX Drone 16K*
  - For the objective evaluation, Y-PSNR is used
  - Lack of time, We experimented only 17 frame
  - We compare SHVC and HEVC-Simulcast
  - SHVC is slightly better, but not significantly.

Sequence	BD-rate	DeltaQP	Group of Pictures (GOP)	Frame	Tile Scheme (EL)
<i>Lake Park Riding 16K</i>	-4.20%	5	16	17	20x20 Unifrom
<i>Ilsan KINTEX Drone 16K</i>	-7.52%	5	16	17	20x20 Uniform

Results of SHVC BD-rate compare to HEVC-Simulcast

# Experimental Results (-Cont'd)

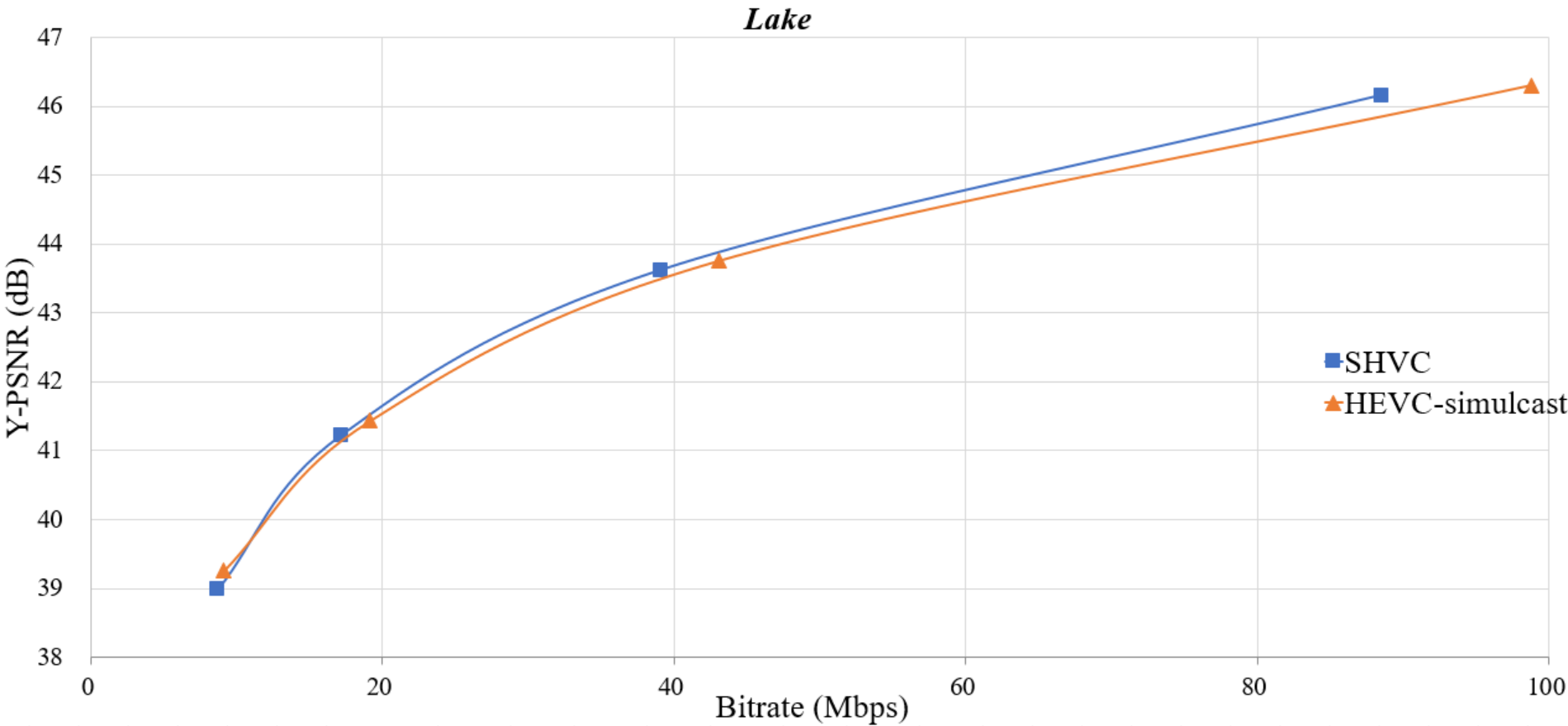

RD-curve of *Lake Park Riding 16K*

# Experimental Results

*Drone*

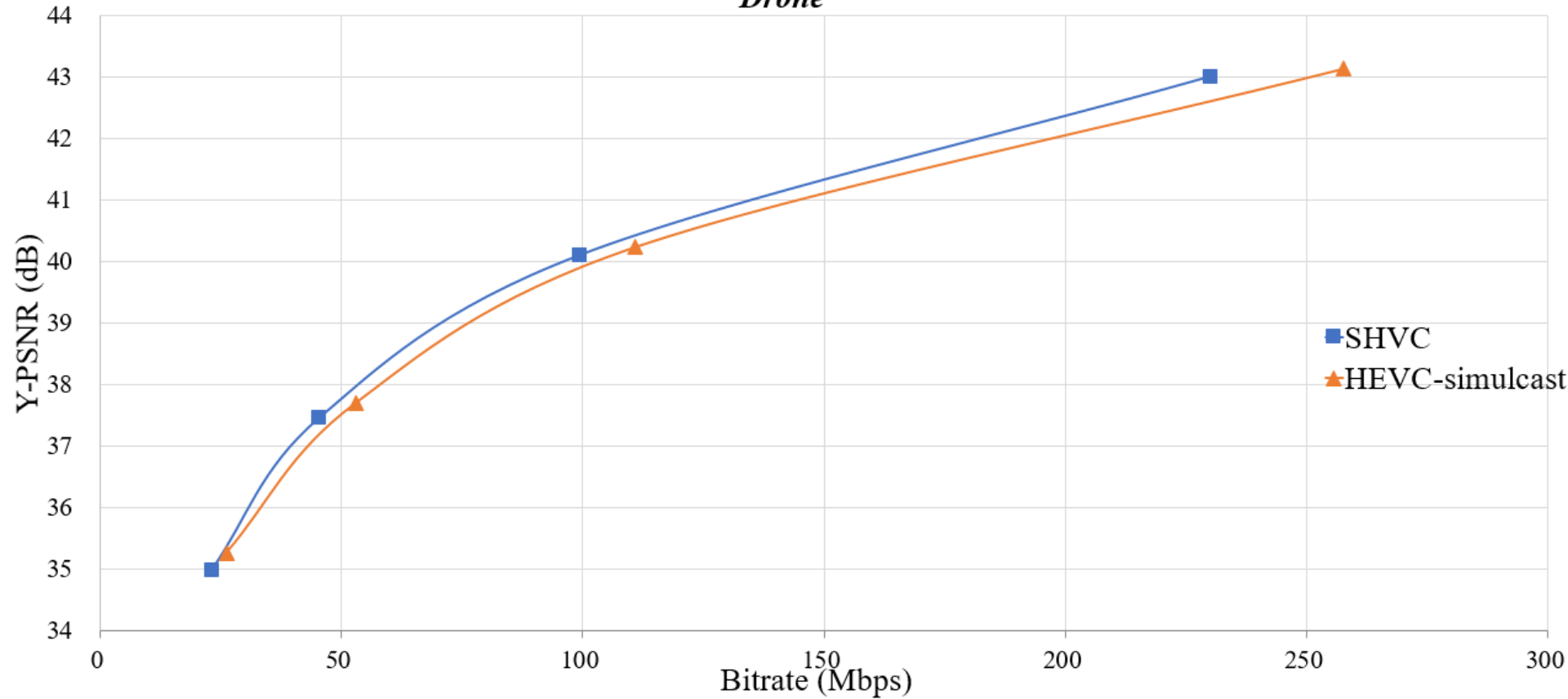

RD-curve of *Ilsan KINTEX Drone 16K*